

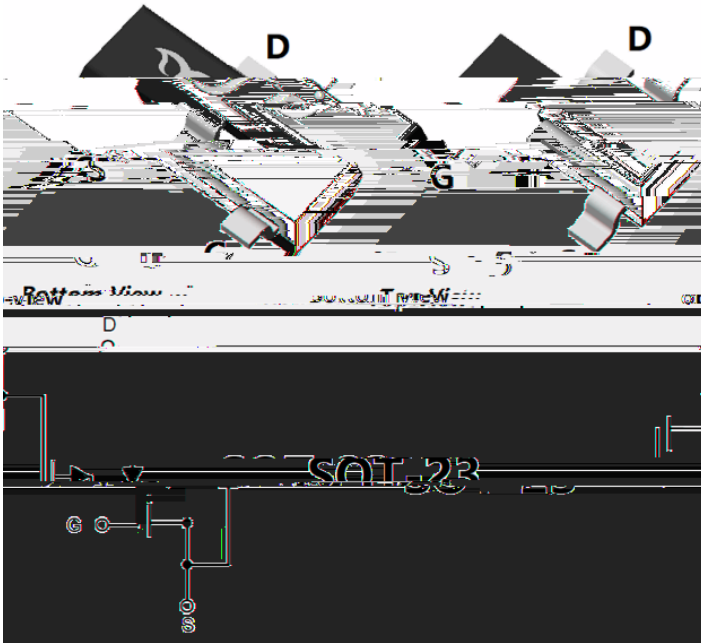

P-Channel Enhancement Mode Field Effect Transistor



Product Summary

V_{DS}	-30V
I_D	-4.1A
$R_{DS(ON)}$ (at $V_{GS}=-10V$)	49mohm
$R_{DS(ON)}$ (at $V_{GS}=-4.5V$)	65mohm

General Description

Trench Power LV MOSFET technology
 High density cell design for Low $R_{DS(ON)}$
 High Speed switching
 Part no. with suffix "Q" means AEC-Q101 qualified

Applications

Battery protection
 Load switch
 Power management

Absolute Maximum Ratings ($T_A=25$ unless otherwise noted)

Parameter	Symbol	Limit	Unit
Drain-source Voltage	V_{DS}	-30	V
Gate-source Voltage	V_{GS}	± 20	V
Drain Current	I_D	$T_A=25$	-4.1
		$T_A=70$	-3.2
Pulsed Drain Current ^A	I_{DM}	-15	A
Total Power Dissipation	P_D	$T_A=25$	1.2
		$T_A=70$	0.8
Thermal Resistance Junction-to-Ambient ^B	R_{JA}	105	/W
Junction and Storage Temperature Range	T_J, T_{STG}	-55 +150	

Ordering Information (Example)

PREFERRED P/N	PACKING CODE	Marking	MINIMUM PACKAGE(pcs)	INNER BOX QUANTITY(pcs)	OUTER CARTON QUANTITY(pcs)	DELIVERY MODE
YJL3407AQ	F2	3407.	3000	30000	120000	7" reel



Typical Performance Characteristics

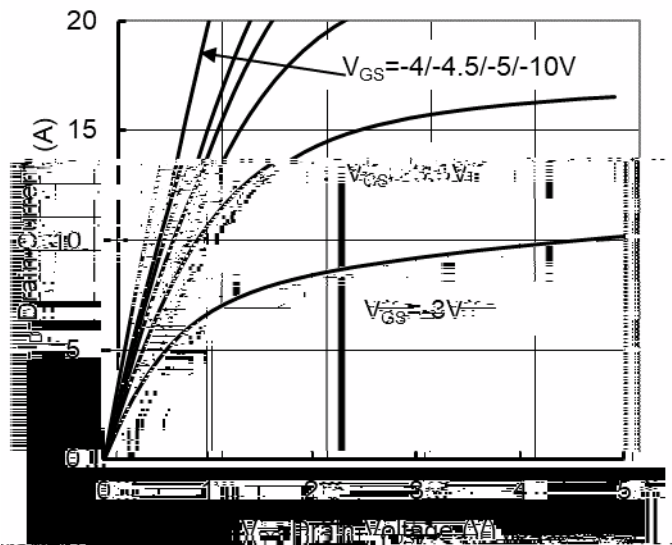

Figure1. Output Characteristics

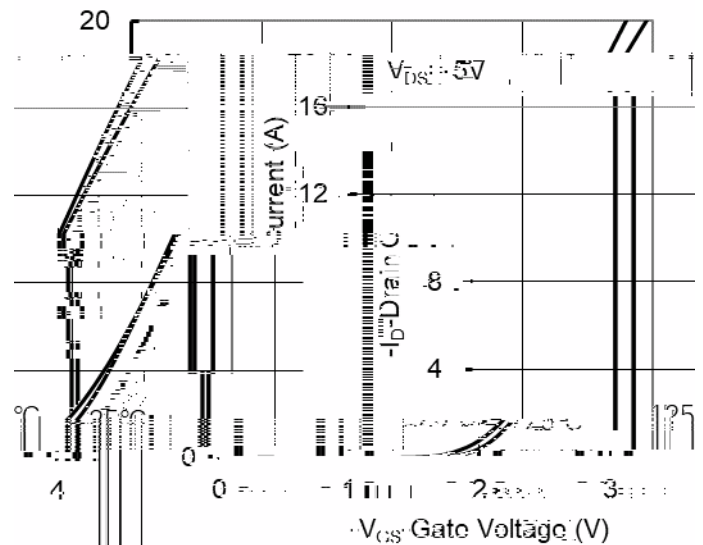

Figure2. Transfer Characteristics

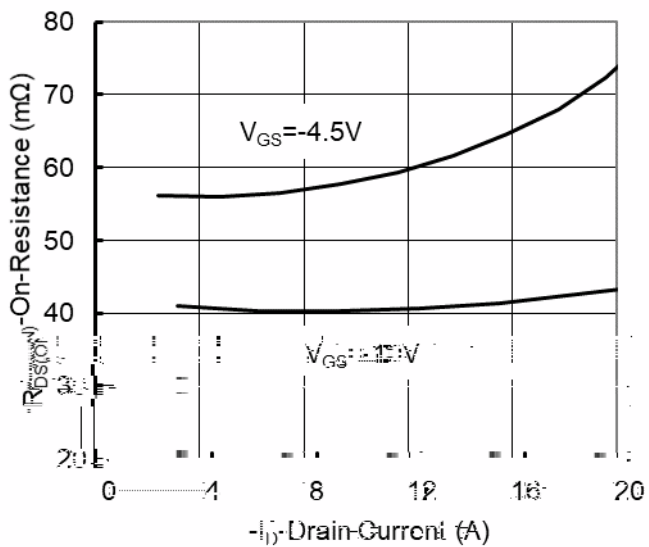

Figure 3: On-Resistance vs. Drain Current and Gate Voltage

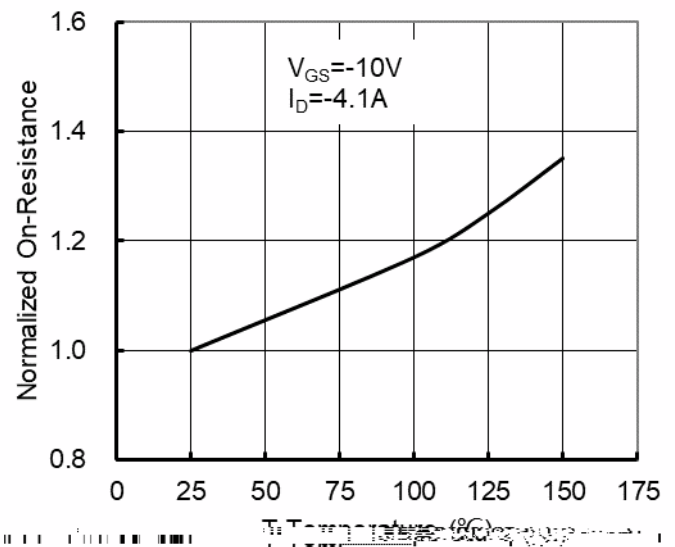

Figure 4: On-Resistance vs. Junction Temperature

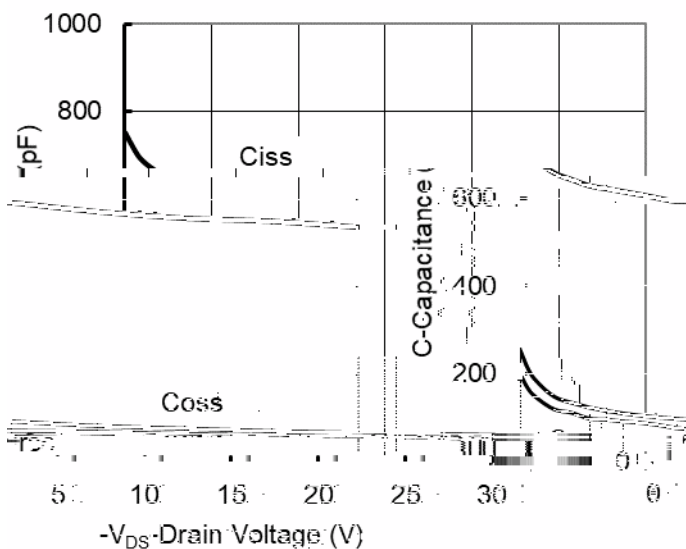

Figure5. Capacitance Characteristics

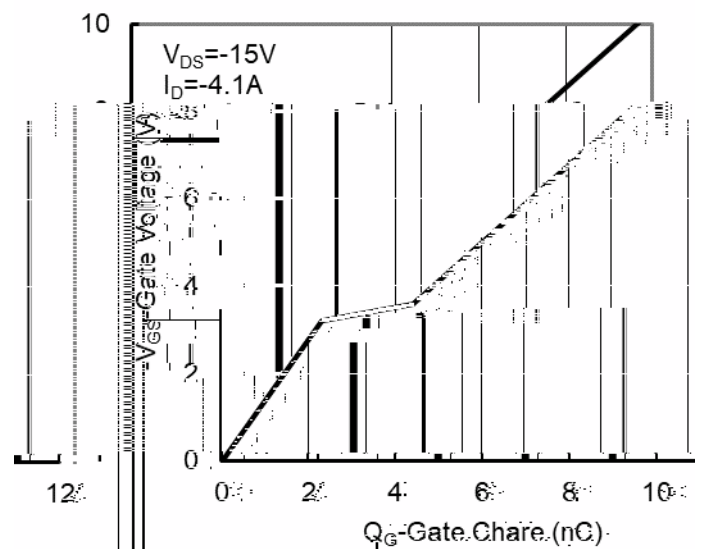

Figure6. Gate Charge

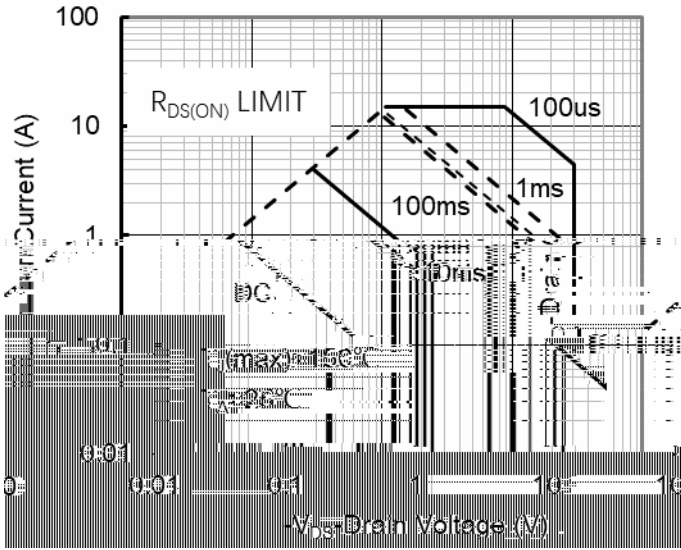

Figure7. Safe Operation Area

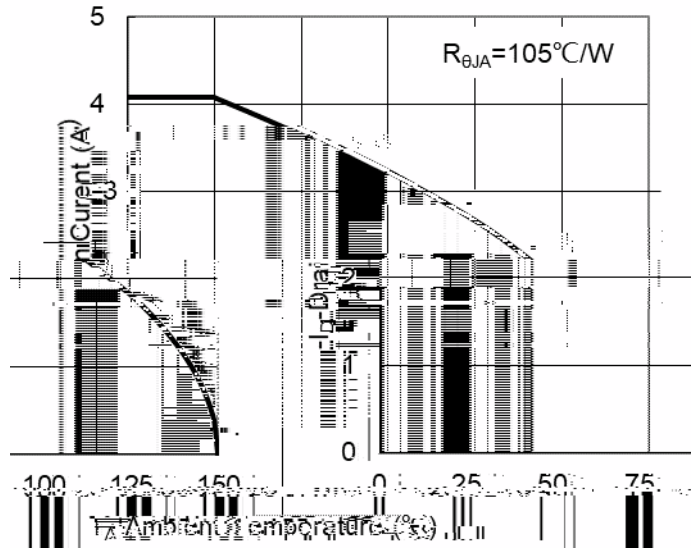

Figure8. Maximum Continuous Drain Current vs Ambient Temperature

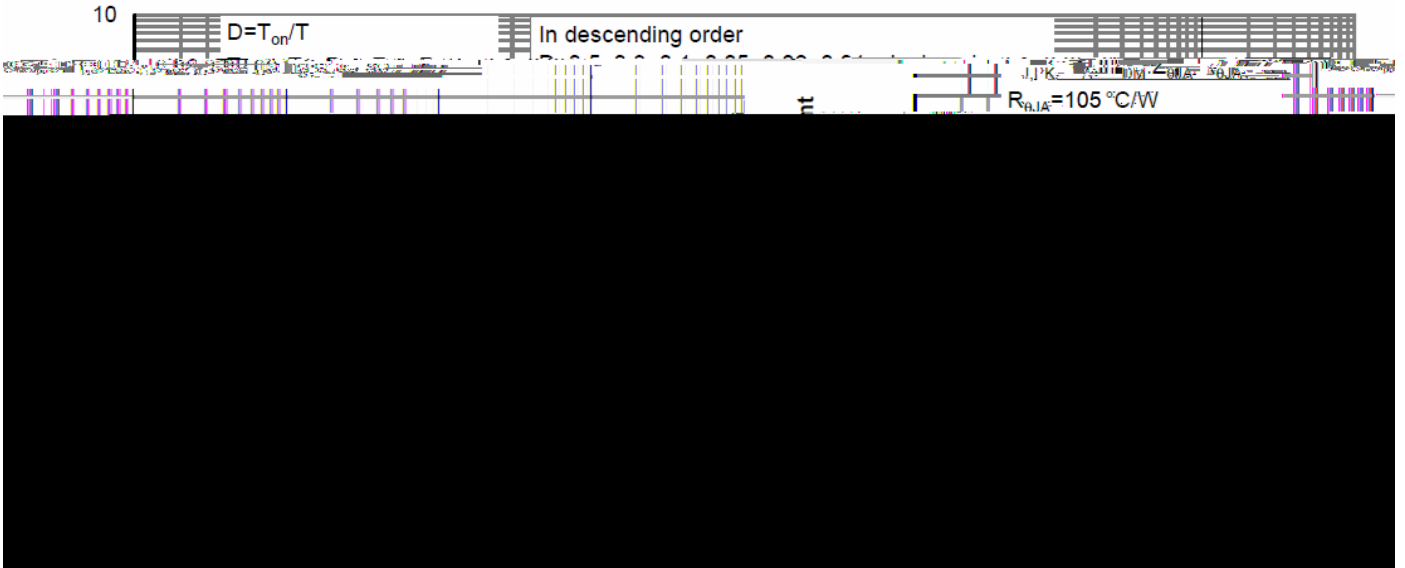
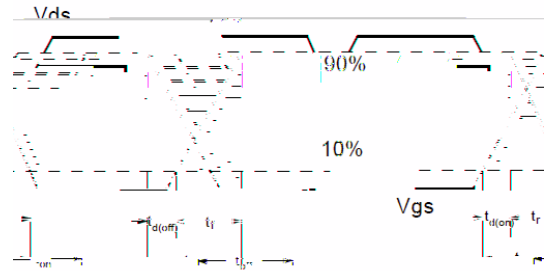
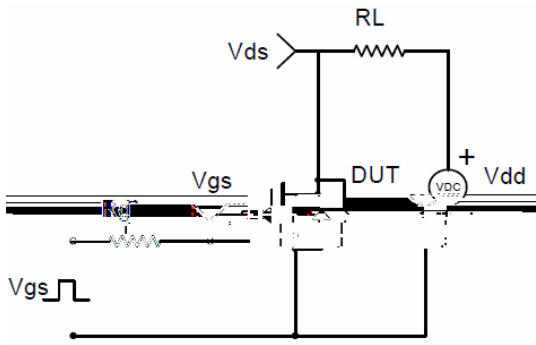
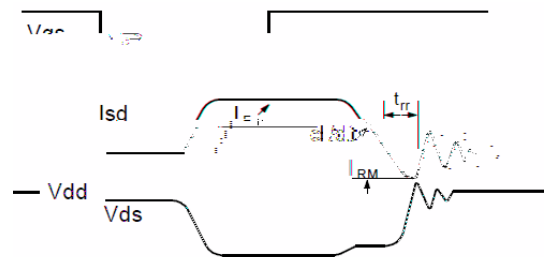
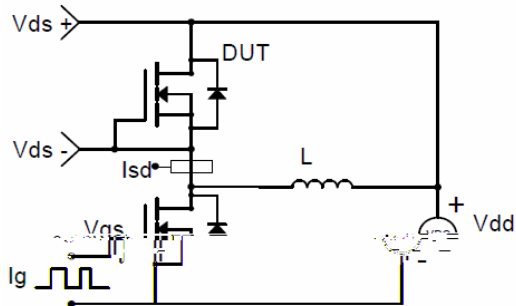

Figure9. Normalized Maximum Transient Thermal Impedance



Resistive Switching Test Circuit & Waveforms



Diode Recovery Test Circuit & Waveforms

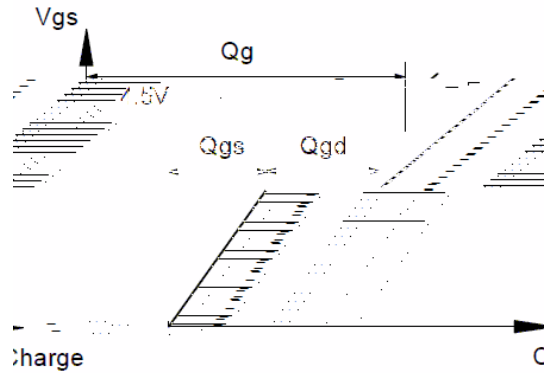
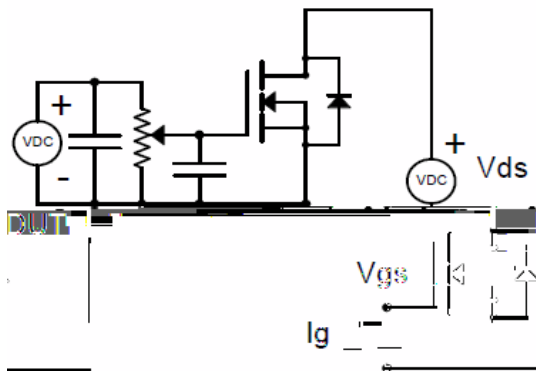

Gate Charge Test Circuit & Waveform

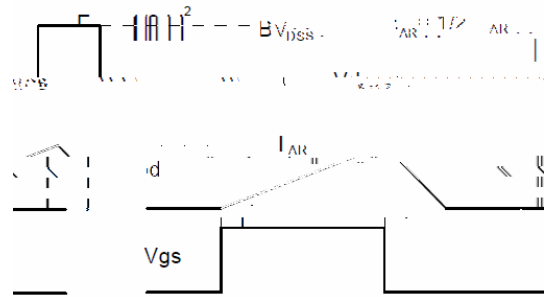
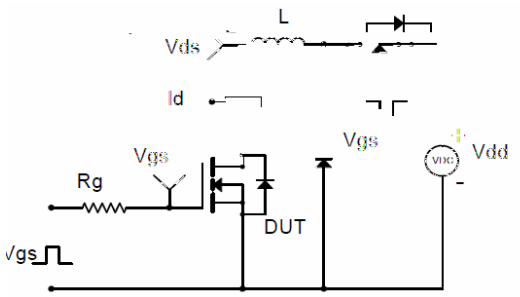

Unclamped Inductive Switching (UIS) Test Circuit & Waveforms

< - / \$ 4

v 6 2 7 3 D F N D J H L Q I R U P D W L R Q

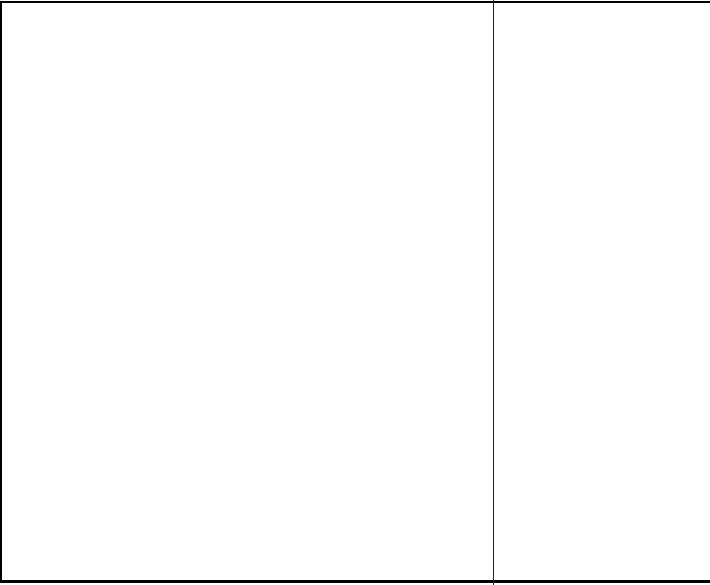

' , 0	, 1 & + (6		0 0		1 2 7 (
	0 , 1	0 \$;	0 , 1	0 \$;	
\$					
\$					
\$					
E					
F					
.					
(
(
H	7 < 3		7 < 3		
H					
/	5 ()		5 ()		
/					
				f	

v 6 2 7 6 X J J H V W H G 3 D G / D \ R X W

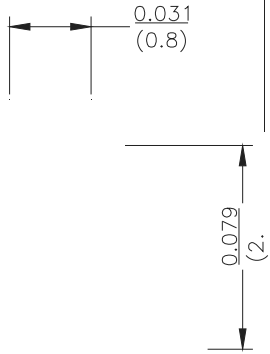



Disclaimer

The information presented in this document is for reference only. It is not intended to be used as a substitute for professional advice. The user should consult the relevant technical specifications and standards for the product. The manufacturer is not responsible for any damage or loss caused by the use of the product.